



TAKE OFF WITH US

Memphis

INTERNATIONAL AIRPORT

Pre-Bid Conference

Winchester TWY Y Bridge –

Electrical Damage Repair – Construction

MSCAA Project No. 19-1423-22-01

Thursday, May 12, 2022; 10:00 a.m. - 11:00 a.m.

MEETING AGENDA

- Welcome
- Introductions
- Bid Package Submittal
- Sign-In Sheet
- Site Visit
- Q & A Process
- Anticipated Date Sequence
- Procedures, Protocol, and General Contract Requirements
- Project Scope, Phasing, and Technical Review
- Q&A Session

USING ZOOM

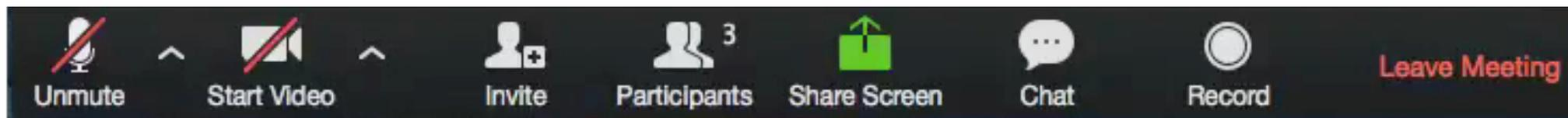

↑
unmute mic
only when it's
your turn to
speak



↑
turn webcam
on/off



↑
raise your hand
or view who else
is in the meeting



↑
share your
screen when
it's your turn to
present

↑
join the chat
discussion or
share links

↑
leave the
meeting at
the end of
class

INTRODUCTIONS, RESPONSIBILITIES, AND LINES OF COMMUNICATION

Project Team:

Owner:

Memphis-Shelby County Airport Authority (MSCAA)

Designer:

Renaissance Group / Barge Design Solutions

BID PACKAGE SUBMITTALS



FLIGHTS ▾ PARKING & TRANSPORTATION ▾ PASSENGER GUIDE ▾ ABOUT MEM ▾ CONNECT ▾

Proposal documents are available online at www.flymemphis.com/rfps-rfq.



| Bid / RFP / RFQ Name | Date Issued | Sealed Proposals will be received by: |
|---|----------------|---------------------------------------|
| Winchester TWY Y Bridge - Electrical Damage Repair - Construction RFB No.: 19-1423-22-01 | April 28, 2022 | May 26, 2022 at 2pm Central Time |

- BID DOCUMENTS**
- [Specifications](#)
 - [Drawings](#)
 - [Proposal Package](#)

PRE-BID MEETING
A Virtual Pre-Bid Meeting will be held **Thursday, May 12, 2022 at 10:00 a.m.** local time via phone/video conferencing.
Link: <https://us06web.zoom.us/j/84890254821?pwd=WjhEY1V5bWd5YkFMStYtWRE0rWld4Zz09>; phone: (301) 715 8592; meeting ID: 848 9025 4821; passcode: 524005.

Instructions on Pre-Bid Meeting and Site Visit request can be found at <https://www.flymemphis.com/rfps-rfq>. Attendance at the Pre-Bid Meeting is strongly recommended.

QUESTIONS
Questions regarding this RFB must be submitted in written form via email - winchesteryankee@flymemphis.com. Questions will be accepted until 5:00 PM, May 17, 2022. Responses will be posted by Friday, May 20.

LEGAL NOTICE
Please [click here](#) to download the Legal Notice.

Search ...

TRANSLATE

English ▾

NAVIGATE

- Home
- Flights
- Parking & Transportation
- Passenger Guide
- About MEM
- Modernization: A Better MEM
- Press Room
- Connect

Please check for updates, addendums, etc.



BID PACKAGE SUBMITTALS

Bid Package **Required** Contents:

- Bid Envelope
- Proposal (Specification 00405)
- Proposal Guarantee (Specification 00410)
- DBE Assurance Statements – one each per DBE partner (Specification 00445)
- DBE Goals Accomplishment Statement (Specification 00445)
- Information on All Firms that Provide Bids or Quotes (Specification 00445)
- Written quote or proposal or other communication from each DBE upon which the scope of work and dollar value contained in your Assurance Statements is based with items included in the Proposal either circled and/or highlighted.
- Signed Addenda (if applicable)
- Summary (on company letterhead) of respondent's proposed team, qualifications, and schedule.

Refer to Specification 00200 – Instructions to Bidders/Proposers for full instructions

BID PACKAGE SUBMITTALS

Submit proposals to:

MSCAA Procurement Department
4150 Louis Carruthers Drive
Memphis, TN 38116

Proposals due:

Thursday, May 26, 2022
2:00 p.m., local time

Approx. 30 minutes after, bids will be opened and publicly read via teleconference phone: (646) 876- 9923; meeting ID: 892 3923 7003; passcode: 929866.

Bids are good for seventy-five (75) days.

BID PACKAGE SUBMITTALS



**Procurement Warehouse
4150 Louis Carruthers Drive**

Louis Carruthers Drive

Shelby Drive



SIGN IN SHEET

- Although this is a NOT mandatory pre-bid meeting, all Prime Contractors who intend to submit a proposal are encouraged to sign-in to register their attendance.
- Before leaving the call, please send an email to winchesteryankee@flymemphis.com stating your name, company name, prime or sub contractor, email address and office and cell phone numbers; a list of call participants will be available upon request.

SITE VISIT

The project site is available for inspection at any time and site visits are self guided.

If warranted, MSCAA-led site visits can be scheduled by sending an email to winchesteryankee@flymemphis.com. Each visit will be thirty (30) minutes and limited to two persons per company.

OVERALL SCOPE OF WORK:

The scope of work consists of electrical replacement of wire trough, circuit breakers, wire connectors, etc. as notated in the construction documents.

Q&A PROCESS

- Please utilize the Zoom chat option to ask questions during the pre bid.
- All questions **must** be submitted to winchesteryankee@flymemphis.com questions not submitted in this manner will not be provided with a formal answer.
- Question deadline: 5:00 p.m. local time, **Tuesday, May 17, 2022.**

ANTICIPATED DATE SEQUENCE

- Questions submitted by the deadline and responses will be included in an addendum; the addendum will be posted to the website not later than **Friday, May 20, 2022.**
- Award/Contract – *Precise timing to be determined.*
- General sequence:
 - Identification of lowest responsive bidder – May 2022
 - Notice of Intent to Award – May 2022
 - Contract Review/Execution – June 2022
 - NTP – June 2022
 - Completion – August 2022

*Continue to monitor www.flymemphis.com website for addenda after **5/18/2022**

Procedures, Protocol, and General Contract Requirements



GENERAL CONTRACT REQUIREMENTS

DBE Requirements – Section 00445

Joe Claiborne – Senior Manager,
Business Diversity Development

DBE Goal: 26%

4/28/2022

MSCAA 19-1423-22-01

DIVISION 0 – SECTION 00445

DISADVANTAGED BUSINESS ENTERPRISE (DBE) REQUIREMENTS

MSCAA operates a federal Disadvantaged Business Enterprise (DBE) Program and a non-federal Business Diversity Development Program (BDDP) to ensure full and fair opportunities in MSCAA contracting for businesses owned by socially and economically disadvantaged individuals. Memphis-Shelby County Airport Authority (MSCAA) administers both programs according to the regulations that apply to the federal program, primarily 49 CFR Part 26. Because the BDDP program applies to contracts involving non-federal funds, not every aspect of 49 CFR Part 26 is relevant to the BDDP program. In most areas, 49 CFR Part 26 will guide our operation of the BDDP including, but not necessarily limited to, rules dealing with certification and counting participation. Only firms that are certified consistent with 49 CFR Part 26 and by the MSCAA or Tennessee Department of Transportation Unified Certification Program (TN UCP), as identified below, will be considered to be certified as a Disadvantaged Business Enterprise.

This section, entitled “Disadvantaged Business Enterprise Requirements” is provided in an effort to assist Respondents. The information contained in this section is not intended to, nor does it, supplement or amend any federal regulation. All Respondents are responsible for compliance with all applicable federal and MSCAA rules and requirements.

It is a requirement that all Respondents providing services for the MSCAA take all reasonable steps to ensure that DBE have a full and fair opportunity to compete for and perform contract work without discrimination on the basis of age, race, sex, color, national origin, creed, religion, sexual orientation or disability. In order to satisfy this requirement, Respondents will be expected to timely submit documentation as identified below and throughout the contract period if selected, and cooperate with MSCAA. Failure to timely submit requested documentation, cooperate with MSCAA or answer inquiries truthfully will be considered a material contract breach and may result in termination.

The following documents must be submitted with your response to this solicitation:

DBE Assurance Statement/Letter of Intent. The Respondent must submit an Assurance Statement for each DBE whose participation the Respondent is counting toward the goal. This may include first, second, third and so on tier subcontractors and the Respondent and all subcontractors between the Respondent and the DBE should sign the Assurance Statement. The Respondent must submit this Assurance Statement on Company Letterhead.

For each Assurance Statement, the Respondent must also provide the written quote or proposal from the DBE or other communication from the DBE upon which the scope of work and dollar value contained in your Assurance Statement is based (“quote/proposal”).

For all RFQs using federal monies, the Assurance Statement(s) must still be submitted and list the DBE s to be used and their scope of work, but no dollar amount(s) is entered. Dollar amounts(s) will be submitted by the prevailing Respondent upon completion of the selection process.

All portions of the Assurance Statement must be completed (including the description of work, the estimated contract amount, and the estimated dollar value of DBE participation for counting and goal purposes) before the Assurance Statement is signed by either the DBE or the Respondent. If the DBE’s, and if applicable the 2nd/3rd Tier Subcontractor’s, signature(s) can be obtained on the completed Assurance Statement before the bid

GENERAL CONTRACT REQUIREMENTS

DBE Requirements

4/28/2022 MSCAA 19-1423-22-01

Project No. _____

DBE ASSURANCE STATEMENT/LETTER OF INTENT

RESPONDENT:

Name of Firm: _____
Address: _____
City: _____ State: _____ Zip: _____
Telephone: _____

DBE:

Name of Firm: _____
Address: _____
City: _____ State: _____ Zip: _____
Telephone: _____

Description of work to be performed by DBE:

The Respondent is committed to utilizing the above named DBE for the work described above. The estimated dollar value of this work is \$ _____, which is _____% the total base bid proposal.

AFFIRMATION

The above-named DBE affirms that it will perform the portion of the contract for the estimated dollar value as stated above.

By: _____
Signature of DBE and Title Date Name

By: _____
Signature of 2nd/3rd Tier Subcontractor Date Name
and Title

If the Respondent does not receive award of the prime contract, any and all representations in this letter of Intent and Affirmation shall be null and void.

By: _____
Signature of Respondent and Title Date Name

(SUBMIT ON RESPONDENT'S LETTERHEAD FOR EACH DBE SUBCONTRACTOR.)

00445 ISSUED FOR BID Page 8

4/28/2022 MSCAA 19-1423-22-01

Project No. _____

RESPONDENT DBE GOALS ACCOMPLISHMENT STATEMENT

The undersigned Respondent has satisfied the requirements of the bid/proposal specification in the following manner (please complete the appropriate spaces):

_____ The Respondent is committed to a minimum of **26%** DBE utilization on this contract.

_____ The Respondent is unable to meet the DBE goal of **26%** but is committed to a minimum of _____% DBE utilization on this contract and submits the attached narrative and documentation demonstrating good faith efforts consistent with Appendix A of 49 CFR 26. The Respondent should attach as many pages as necessary to provide a full and complete narrative and supporting documentation of good faith efforts made. This narrative must be written on company letterhead and signed.

Please provide an explanation for the percentage quoted above:
Provide an explanation of the dollar value of DBE's participation and compensation and how this has been determined to meet the specific goal requirements of this solicitation in whole or part.

If DBE and company will enter into a Joint Venture, please describe the terms of the relationship and attach a copy of the contract between the parties.

It is the present intent of the Respondent to utilize the specific DBE firms identified in this proposal in the execution of this contract. If for any reason, one or more of the DBE identified here are unable or unwilling to participate, the Respondent will make good faith efforts to replace the DBE with a similar DBE. The Authority DBE Good Faith Procedures are provided in this package and apply to this proposal.

Respondent's Name: _____

State Registration No.: _____

Federal Tax ID No.: _____

By: _____
Signature and Title Date

(SUBMIT THIS PAGE ON RESPONDENT'S LETTERHEAD)

00445 ISSUED FOR BID Page 9

GENERAL CONTRACT REQUIREMENTS

DBE Requirements

4/28/2022

MSCAA 19-1423-22-01

Project No. _____

VOLUNTARY DISCLOSURE OF RESPONDENT DATA

For Title VI Compliance, we ask for voluntary disclosure of the following information:

Gender: Male

Female

Race: Caucasian

Black American

Hispanic American

Native American

Subcont. Asian American

Asian-Pacific American

Other (please specify) _____

(DO NOT SUBMIT THIS PAGE ON LETTERHEAD)

00445

ISSUED FOR BID

Page 10



GENERAL CONTRACT REQUIREMENTS

Airport Construction Safety Requirements – Section 00801 & 00500-Exhibit D

Aaron Hascher, CM & ACE
MSCAA - Safety Program Manager

4/28/2022 MSCAA 19-1423-22-01

DIVISION 0 – SECTION 00801 AIRPORT CONSTRUCTION SAFETY REQUIREMENTS

PART 1 GENERAL

1.01 SUMMARY

- A. This section contains the minimum level of safety requirements for construction projects at Memphis International Airport, General DeWitt Spain Airport, and/or Charles W. Baker Airport.
- B. Related work:
 - 1. Other contract documents affecting construction safety include, but are not limited to, the DIVISION 0 AND DIVISION 1 specifications.

PART 2 PRODUCTS

Not used.

PART 3 EXECUTION

3.01 CONTRACTOR PERSONNEL SAFETY ORIENTATION

- A. The Contractor shall be responsible for briefing all construction personnel on the requirements contained in this section prior to their working in the construction area and at periodic intervals throughout the course of the contract. These briefings will be documented in writing.

3.02 SCHEDULING WORK

- A. See Specification section 01100, SEQUENCE OF CONSTRUCTION & LIQUIDATED DAMAGES.
- B. See General Provision Section 80, Paragraph 80-04, Limitation of Operations.

3.03 CONSTRUCTION SECURITY

- A. See Specification section 00802, AIRPORT SECURITY REQUIREMENTS.

3.04 LIMITATION ON CONSTRUCTION

- A. The limits of construction, material storage areas, equipment parking and other areas defined as available for the contractor's exclusive use during construction shall be identified and defined by the contractor prior to starting work on the project. Temporary barricades, flagging and flashing caution lights may be required at access points, taxiway crossings and pavement tie-ins. The type markings, barricades and flashing caution lights are designated on the construction plans and must be inspected and approved by the Airport Authority.
- B. The Contractor shall store all materials and park construction equipment, when not in use only in the areas designated on the plans or during the pre-construction conference.
- C. Stockpiling of dirt and construction materials shall be constrained in a manner preventing movement resulting from jet blast or wind in excess of 10 knots.
- D. Construction debris, waste, wrappings or loose material capable of causing damage to aircraft

00801

ISSUED FOR BID

Page 1

EXHIBIT D TO LUMP SUM CONSTRUCTION CONTRACT FOR WINCHESTER TWY Y BRIDGE - ELECTRICAL DAMAGE REPAIR – CONSTRUCTION

BY AND BETWEEN
THE MEMPHIS-SHELBY COUNTY AIRPORT AUTHORITY
AND
(CONTRACTOR NAME)

Construction Safety and Health Guidelines



Non-OCIP Safety Program

| Revision | Revision Summary | Date |
|----------|--|------------|
| 1 | Amendments for clothing to include "reflective safety vests" | 02/06/2017 |

Page 37

Contract: Contractor Name
Winchester TWY Y Bridge – Electrical Damage Repair - Construction
MSCAA Project No. 19-1423-22-01

CONTRACTOR PLANS/PROGRAMS

The drawings were designed in accordance with the Uniform Manual of Traffic Control Devices (MUTCD); contractor safety plans should include but are not limited to the following:

- Site Traffic Control Plan
- Fire Protection Plan
- Hazard Communication Program
- Hearing Conservation Program
- Dust Control Plan
- Debris Control Plan
- General Housekeeping
- General Duty Clause
- Compressed Gas Storage/Use
- Electrical Safety/Flash ARC
- Lockout/Tagout (LOTO)

The safety plans must be submitted for review by the MSCAA Safety Program Manager.

GENERAL CONTRACT REQUIREMENTS

Safety

- Contractor shall develop their own written site-specific safety and health plans for the Memphis-Shelby County Airport Authority
- Your Safety and Health Plan shall, at a minimum, meet the requirements of 29 CFR1926 – Federal OSHA Construction regulations
- Each Contractor is responsible for protecting the health and safety of its employees and the employees of each subcontractor and sub-subcontractor while ensuring they have a safe and healthful place to work
- The site-specific safety and health program shall be submitted for approval within fifteen (15) days after the Notice to Proceed for approval to the Project Safety Manager
- Impact of claims will affect the contractor's own experience mod
- Have an active return to work program
- Communications/ Memphis Airport Police are to be contacted in case of emergency: 901 922 8298

CITY OF MEMPHIS TRAFFIC CONTROL PLANS

The documents have been sent to the City of Memphis Traffic Engineering division for review; the work is anticipated to take place within two to three days between the hours of 9:00 a.m. and 4:00 p.m.; final dates and hours for construction will be determined by the selected bidder.

The project includes one eastbound lane closure on Winchester Road between the UPS entrance and one of the airports' taxiways, TWY "Yankee" east of Airways Boulevard. The contractor will be required to open the lanes back up when workers are not present.

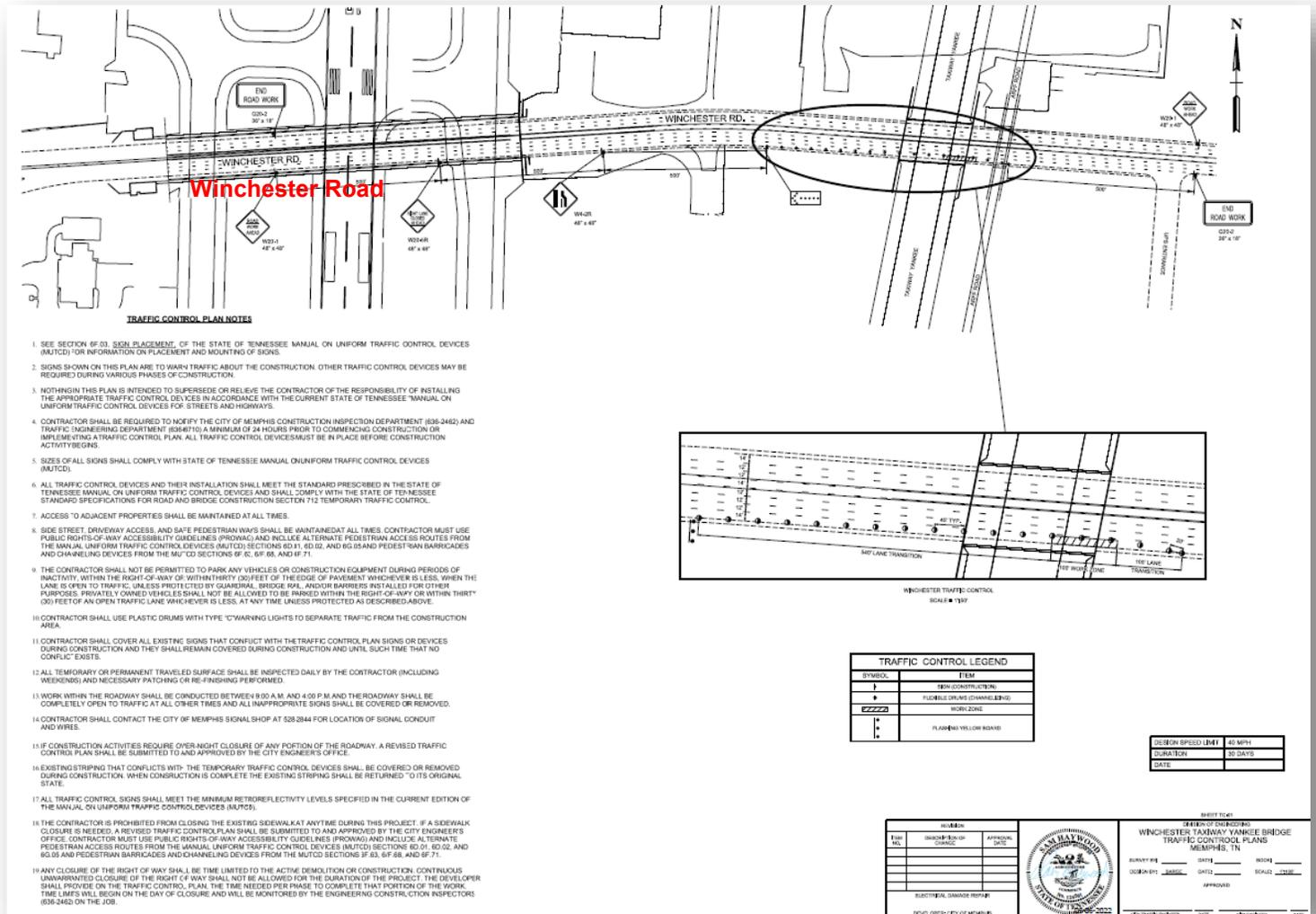

CITY OF MEMPHIS TRAFFIC CONTROL PLANS



Area of work

ACORD CERTIFICATE OF LIABILITY INSURANCE DATE (MM/DD/YYYY) 06/07/2013

THIS CERTIFICATE IS ISSUED AS A MATTER OF INFORMATION ONLY AND CONFERS NO RIGHTS UPON THE CERTIFICATE HOLDER. THIS CERTIFICATE DOES NOT AFFIRMATIVELY OR NEGATIVELY AMEND, EXTEND OR ALTER THE COVERAGE AFFORDED BY THE POLICIES BELOW. THIS CERTIFICATE OF INSURANCE DOES NOT CONSTITUTE A CONTRACT BETWEEN THE ISSUING INSURER(S), AUTHORIZED REPRESENTATIVE OR PRODUCER, AND THE CERTIFICATE HOLDER.

IMPORTANT: If the certificate holder is an ADDITIONAL INSURED, the policy(ies) must be endorsed. If SUBROGATION IS WAIVED, subject to the terms and conditions of the policy, certain policies may require an endorsement. A statement on this certificate does not confer rights to the certificate holder in lieu of such endorsement(s).

PRODUCER: [REDACTED] CONTACT NAME: [REDACTED]
 PHONE: [REDACTED] FAX: [REDACTED]
 (A/C, No. Ext.) [REDACTED] A/C, No.: [REDACTED]
 E-MAIL: [REDACTED]
 ADDRESS: [REDACTED]

INSURER(S) AFFORDING COVERAGE NAIC #
 INSURER A: [REDACTED] [REDACTED]
 INSURER B: [REDACTED]
 INSURER C: [REDACTED]
 INSURER D: [REDACTED]
 INSURER E: [REDACTED]
 INSURER F: [REDACTED]

COVERAGES CERTIFICATE NUMBER: 34071839 REVISION NUMBER:

THIS IS TO CERTIFY THAT THE POLICIES OF INSURANCE LISTED BELOW HAVE BEEN ISSUED TO THE INSURED NAMED ABOVE FOR THE POLICY PERIOD INDICATED. NOTWITHSTANDING ANY REQUIREMENT, TERM OR CONDITION OF ANY CONTRACT OR OTHER DOCUMENT WITH RESPECT TO WHICH THIS CERTIFICATE MAY BE ISSUED OR MAY PERTAIN, THE INSURANCE AFFORDED BY THE POLICIES DESCRIBED HEREIN IS SUBJECT TO ALL THE TERMS, EXCLUSIONS AND CONDITIONS OF SUCH POLICIES. LIMITS SHOWN MAY HAVE BEEN REDUCED BY PAID CLAIMS.

| LINE | TYPE OF INSURANCE | INSUR. NO. | POLICY NUMBER | POLICY EFF. DATE (MM/DD/YYYY) | POLICY EXP. DATE (MM/DD/YYYY) | LIMITS |
|------|---|------------|-----------------------|-------------------------------|-------------------------------|---|
| A | GENERAL LIABILITY <input checked="" type="checkbox"/> CLAIMS-MADE <input type="checkbox"/> OCCUR GEN'L AGGREGATE LIMIT APPLIES PER: <input type="checkbox"/> POLICY <input type="checkbox"/> PRO. <input type="checkbox"/> LOC | X | GNP46993G | 04/01/13 | 04/01/14 | EACH OCCURRENCE \$ 1,000,000 PRODUCTS - COMP/OP AGG \$ 2,000,000 |
| A | AUTOMOBILE LIABILITY <input checked="" type="checkbox"/> ANY AUTO <input type="checkbox"/> ALL OWNED AUTOS <input checked="" type="checkbox"/> HIRED AUTOS <input type="checkbox"/> SCHEDULED AUTOS <input type="checkbox"/> NON-OWNED AUTOS | | GNP46993G | 04/01/13 | 04/01/14 | COMBINED SINGLE LIMIT (EA accident) \$ 1,000,000 BODILY INJURY (Per person) \$ BODILY INJURY (Per accident) \$ PROPERTY DAMAGE (Per accident) \$ |
| | UMBRELLA LIAB <input type="checkbox"/> EXCESS LIAB <input type="checkbox"/> OCCUR <input type="checkbox"/> CLAIMS-MADE DED. RETENTIONS | | | | | EACH OCCURRENCE \$ AGGREGATE \$ |
| | WORKERS COMPENSATION AND EMPLOYERS' LIABILITY ANY PROPRIETOR/PARTNER/EXECUTIVE OFFICER/MEMBER EXCLUDED? (Mandatory in NH) If yes, describe under DESCRIPTION OF OPERATIONS below | | | | | WC STATUT. TORT LIMITS \$ OTHER \$ E.L. EACH ACCIDENT \$ E.L. DISEASE - EA EMPLOYEE \$ E.L. DISEASE - POLICY LIMIT \$ |
| A | Physical Damage | | GNP46993G - ACV BASIS | 04/01/13 | 04/01/14 | COMP / COLL \$0 DEDUCT |
| A | Broad Form Cargo Liab. | | GNP46993G | 04/01/13 | 04/01/14 | 0 Deduct 100,000 |

DESCRIPTION OF OPERATIONS / LOCATIONS / VEHICLES (Attach ACORD 101, Additional Remarks Schedule, if more space is required)
 The City of Memphis is additional insured on the General Liability Policy.

CERTIFICATE HOLDER: The City of Memphis
 125 North Main Street
 Memphis, TN 38103

CANCELLATION: SHOULD ANY OF THE ABOVE DESCRIBED POLICIES BE CANCELLED BEFORE THE EXPIRATION DATE THEREOF, NOTICE WILL BE DELIVERED IN ACCORDANCE WITH THE POLICY PROVISIONS.
 AUTHORIZED REPRESENTATIVE: [REDACTED]
 USA

GENERAL CONTRACT REQUIREMENTS

This **is not** an Owner Controlled Insurance Program (OCIP) project.

Prior to the commencement of any operations by or on behalf of the Contractor relating to the Project, and with respect to any and all such operations, the Contractor shall procure, maintain and provide to Owner and the Program Manager

Evidence of Contractor's **Commercial Automobile Liability Insurance**

Evidence of **Workers' Compensation and Employer's Liability Insurance**

Evidence of Contractor's **Commercial General Liability Insurance**

Evidence of Contractor's **Excess or Umbrella Liability Insurance.**

Evidence of **Contractors Pollution Liability Insurance**

Evidence of **Contractor's Equipment Insurance**

Required coverages can be found in Section 00500 Contract

GENERAL CONTRACT REQUIREMENTS

Airport Security Requirements – Section 00802

- Project Specific Security Requirements

DIVISION 0 – SECTION 00801

AIRPORT CONSTRUCTION SAFETY REQUIREMENTS

PART 1 GENERAL

1.01 SUMMARY

- A. This section contains the minimum level of safety requirements for construction projects at Memphis International Airport, General DeWitt Spain Airport, and/or Charles W. Baker Airport.
- B. Related work:
 - 1. Other contract documents affecting construction safety include, but are not limited to, the DIVISION 0 AND DIVISION 1 specifications.

PART 2 PRODUCTS

Not used.

PART 3 EXECUTION

3.01 CONTRACTOR PERSONNEL SAFETY ORIENTATION

- A. The Contractor shall be responsible for briefing all construction personnel on the requirements contained in this section prior to their working in the construction area and at periodic intervals throughout the course of the contract. These briefings will be documented in writing.

3.02 SCHEDULING WORK

- A. See Specification section 01100, SEQUENCE OF CONSTRUCTION & LIQUIDATED DAMAGES.
- B. See General Provision Section 80, Paragraph 80-04, Limitation of Operations.

3.03 CONSTRUCTION SECURITY

- A. See Specification section 00802, AIRPORT SECURITY REQUIREMENTS.

3.04 LIMITATION ON CONSTRUCTION

- A. The limits of construction, material storage areas, equipment parking and other areas defined as available for the contractor's exclusive use during construction shall be identified and defined by the contractor prior to starting work on the project. Temporary barricades, flagging and flashing caution lights may be required at access points, taxiway crossings and pavement tie-ins. The type markings, barricades and flashing caution lights are designated on the construction plans and must be inspected and approved by the Airport Authority.
- B. The Contractor shall store all materials and park construction equipment, when not in use only in the areas designated on the plans or during the pre-construction conference.
- C. Stockpiling of dirt and construction materials shall be constrained in a manner preventing movement resulting from jet blast or wind in excess of 10 knots.
- D. Construction debris, waste, wrappings or loose material capable of causing damage to aircraft engines, propellers, or landing gear shall not be allowed on active aircraft movement areas. Material meeting this criteria shall be contained and removed immediately from the AOA.

GENERAL CONTRACT REQUIREMENTS

Contractor's Project Schedule – Section 01320

At pre-construction meeting, contractor shall provide a copy of project schedule; it is to be updated weekly as the job progresses.

4/28/2022

MSCAA 19-1423-22-01

DIVISION 1- SECTION 01320

SCHEDULES AND REPORTS

PART 1 GENERAL

1.01 SUMMARY

- A. The work under this Contract shall be planned, scheduled and reported using computerized precedence diagram format of the Critical Path Method in calendar days, unless otherwise specifically provided in the Contract Documents. The Detailed Construction Schedule shall be developed by using the latest revision of Microsoft Project, or approved equal computer software.
- B. Related Work:
1. Documents affecting work of this Section include, but are not necessarily limited to, other Sections of these Specifications.
 2. Other provisions concerning Schedules and Reports are stated to Specification Sections:
01100 – Summary of Work, Sequence of Construction & Liquidated Damages
General Provision Section 60 - Control of Materials
General Provision Section 90 - Measurement and Payment

PART 2 PRODUCTS

Not Used.

PART 3 EXECUTION

3.01 GENERAL REQUIREMENTS

- A. The Detailed Construction Schedule shall be developed by using the latest revision of Microsoft Project, or approved equal computer software that is compatible with Owner's scheduling software.
- B. The primary objectives of the requirements of this section are:
1. to insure adequate planning and execution of the Work by Contractor;
 2. to assist Owner and Engineer in evaluating the progress of the Work;
 3. to provide a mechanism or tool for use by the Owner, Engineer and Contractor in determining and monitoring any actions of the Contractor which may be required in order to comply with the requirements of the Contract relating to the timely completion of the various portions of the Work
- C. The Detailed Construction Schedule, defined in Paragraph 3.04, shall represent the Contractor's commitment and intended plan for completion of the Work in compliance with the Contract. The Contractor will not:
1. Misrepresent to the Owner its planning, scheduling, and coordination of the work;
 2. Utilize schedules different from those provided to the Owner and Engineer for the direction, execution and coordination of the work;
 3. Utilize schedules which are not feasible or realistic; or

01320

ISSUED FOR BID

Page 1



CONTRACTOR ACCESS AND STAGING AREA

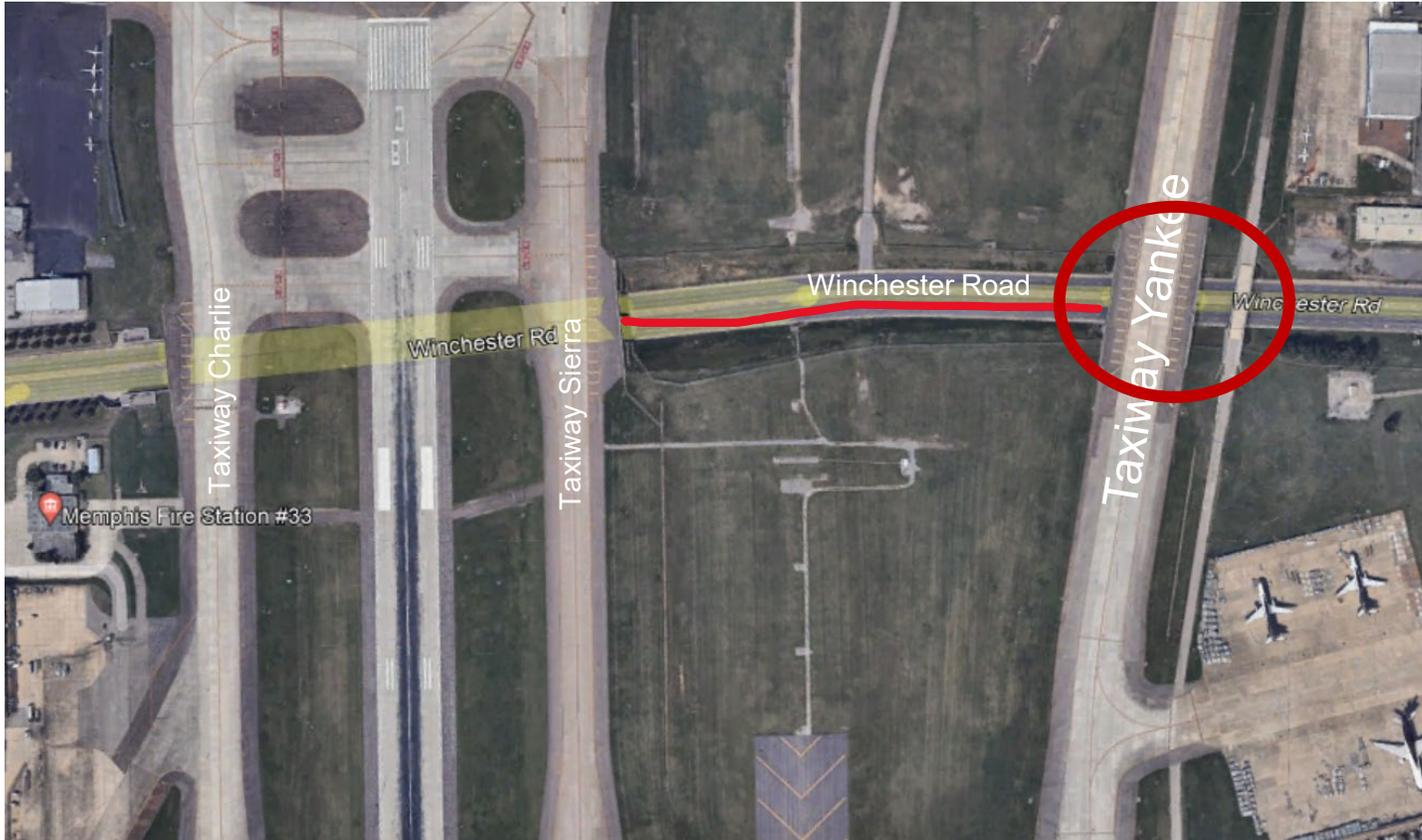

Contractor parking, material delivery, setup, etc. will be discussed in detail at the preconstruction meeting.

For purposes of this meeting, please note **proposed** construction haul route shown in red along Winchester Road.

Project Scope, Phasing, and Technical Review



PROJECT SCOPE OF WORK:

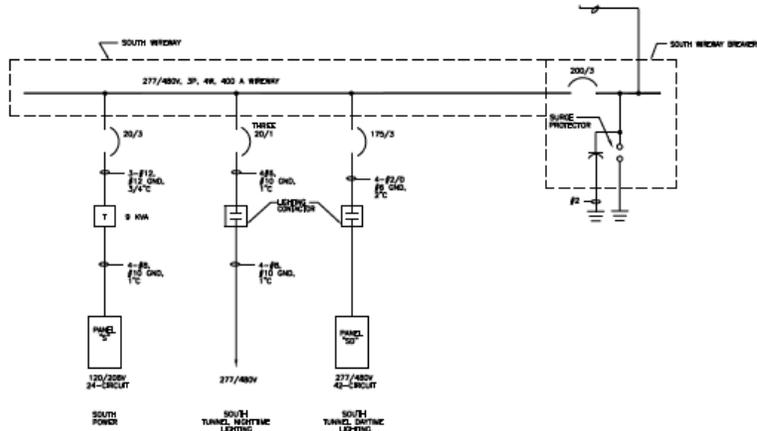

NOTE: ALL WIRING AND CABLES TO ALL NEW AND EXISTING CIRCUIT BREAKERS, PANELS, AND DEVICES ARE TO BE INSTALLED IN THE TUNNEL AND SHALL BE INSTALLED TO PASS THE TEST. REPLACE WIRE CONNECTORS AND INSULATORS TO AND FROM THE WIRE TROUGH. REPLACE THE EXISTING CHALLENGER CIRCUIT BREAKER PANEL FOR CIRCUIT 3. REPLACE SURGE PROTECTORS, REPLACE CONDUIT IN SPOT OUTLET BRACKETS PANEL 50.

| ELECTRICAL LEGEND | |
|--------------------------|---|
| SYMBOL | DESCRIPTION |
| SERVICE AND DISTRIBUTION | |
| ■ | SEPARATOR PANEL |
| — | BRANCHED CIRCUIT PANEL |
| ○ | TRANSFORMER |
| ○ | WIRE CONNECTION |
| ○ | GROUNDING CONNECTION |
| ○ | DISCONNECT SWITCH (SHOWN AS REQUIRED) |
| ○ | WIRE CONDUIT (SHOWN AS OTHER THAN 1/2") |

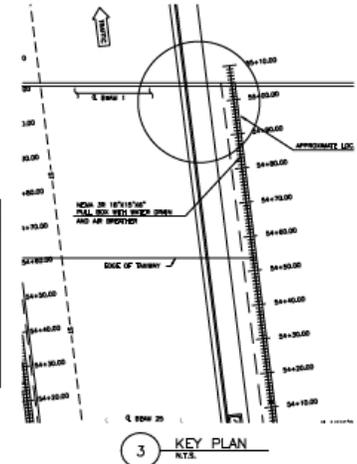

The scope of work consists of replacement of electrical wire trough and six (6) enclosed circuit breakers; replacement of wire connectors, insulators, circuit breaker panel and surge protectors as notated in the construction documents.



2 PHOTO
N.T.S.

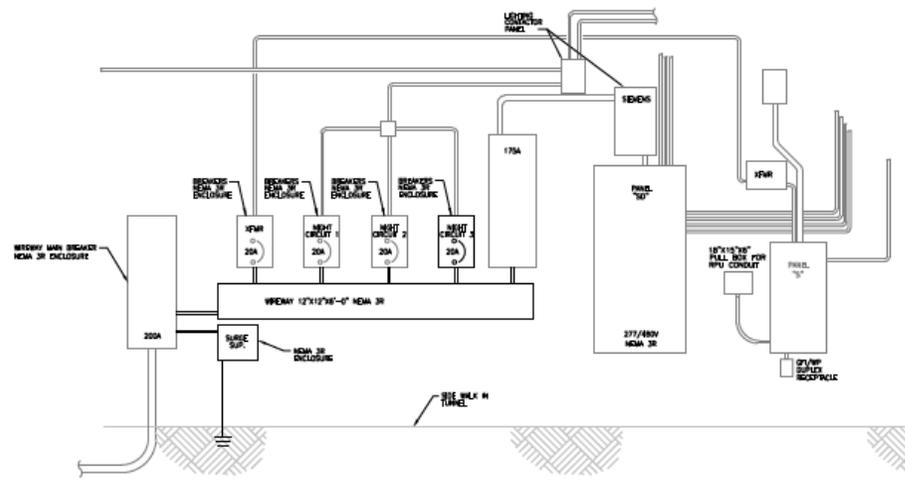

Q&A Session



Q&A SESSION

Remember to submit questions via e-mail to winchesteryankee@flymemphis.com; questions not submitted in this manner will not be provided with a formal answer.

Question deadline: 5:00 p.m. local time, Tuesday, May 17, 2022.



TAKE OFF WITH US



Memphis
INTERNATIONAL AIRPORT